

V-5 & V-10 DRIVE ASSEMBLIES

V-5 GEAR MOTOR DRIVE

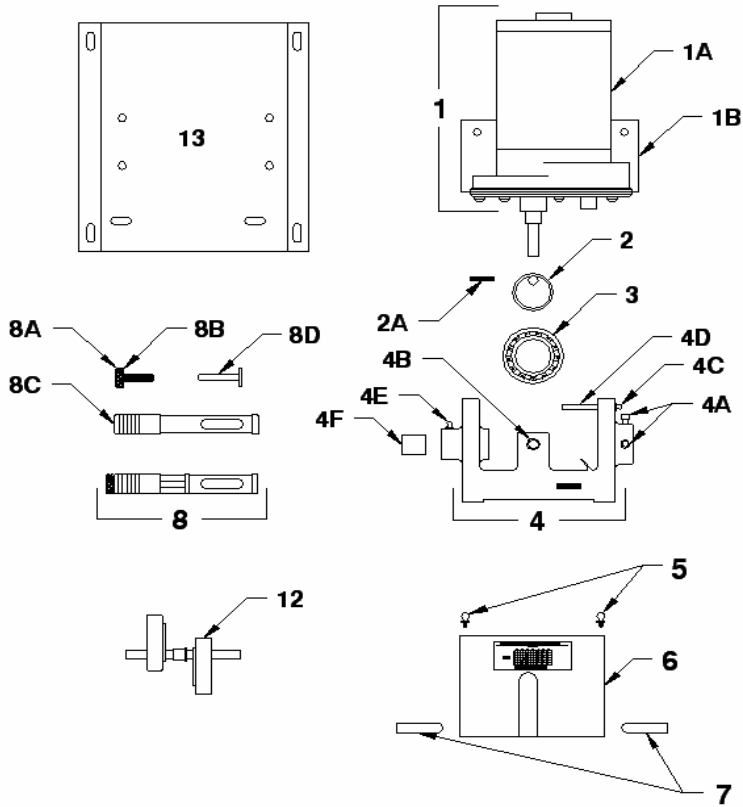

V-5 COUPLING & V-10 FLANGE DRIVE

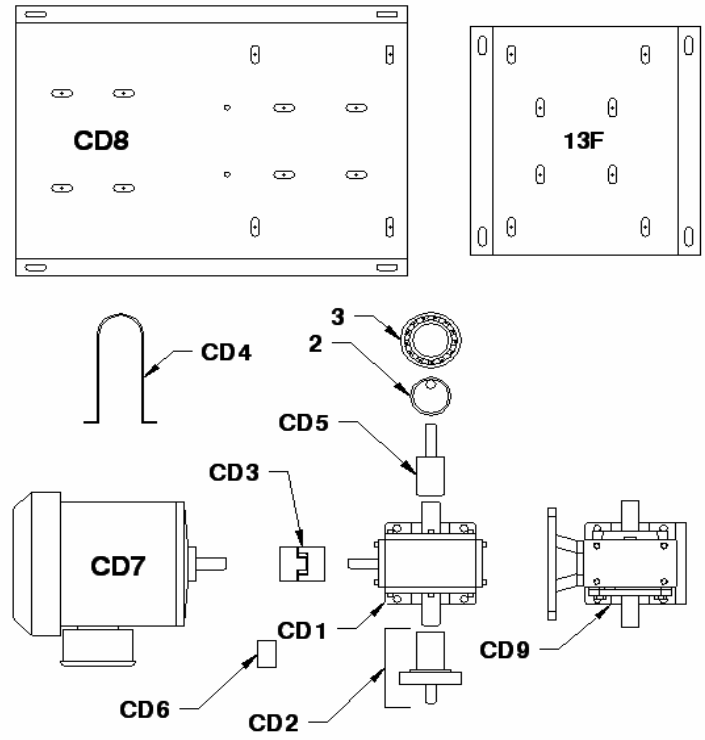

ITEM	PART #	DESCRIPTION
1	5K155A**	12 RPM DRIVE MOTOR & GEAR ASSEMBLY
	5K156A**	6 RPM DRIVE MOTOR & GEAR ASSEMBLY
	5K157A**	18 RPM DRIVE MOTOR & GEAR ASSEMBLY
1A	5K151**	DRIVE MOTOR ONLY FOR GEAR ASSEMBLY
1B	1B-6	6 RPM DRIVE GEAR ASSEMBLY ONLY
	1B-12	12 RPM DRIVE GEAR ASSEMBLY ONLY
	1B-18	18 RPM DRIVE GEAR ASSEMBLY ONLY
2	1101	DRIVE BEARING SUPPORT CAM
2A	1101-1	3/16 X 1 ROLLED DRIVE PIN
3	3L09	DRIVE BEARING
4	008-2	RIGHT HAND BASE CASTING (STANDARD)
	008-2D	INSIDE CASTING ON DUPLEX ASSEMBLY
	008-2L	LEFT HAND BASE CASTING (V-10 DUPLEX)
4A	008-4	1/4-20 X 1/2" ALLEN CAP SCREW (2 REQUIRED)
4B	008-5	5/8" OD X 1/2" ID X 1/2" LONG OILITE BEARING
4C	008-6	5/8" OD X .485" ID X 1/2" LONG OILITE BEARING
4D	006-2	DRIVE BEARING GREASE FITTING
4E	006-3	GREASE TUBE
4F	006-2	SLIDE BUSHING GREASE FITTING
5	008-10	1 1/8" X 1" X 1" OILITE BEARING (2 REQUIRED)
6	1102-1	COVER SCREW (2 REQUIRED)
	1102	CLEAR PLASTIC COVER (STANDARD)
	1102-D	CLEAR PLASTIC COVER (LEFT HAND)
	1102-GC	STAINLESS STEEL GASKETED COVER
7	1102-2	COVER CLIP (2 REQUIRED)
8	A-1097-1	SIMPLEX OR DUPLEX SLIDE ASSEMBLY
8A	1100	SLIDE ADJUSTMENT SCREW
8B	1099	ADJUSTMENT SCREW LOCKNUT
8C	A-1097	SIMPLEX OR DUPLEX SLIDE
8D	1098	SLIDE PIN
12	009	DUPLEX DRIVE SHAFT ASSEMBLY
	009-H	HYDRAULIC DUPLEX DRIVE SHAFT ASSEMBLY
13	BPS	V-5 SIMPLEX BASE PLATE
	BPD	V-5 DUPLEX BASE PLATE
13F	FBP	V-10 SIMPLEX & DUPLEX BASE PLATE

ITEM	PART #	DESCRIPTION
CD1	192A02-20:1	90 RPM COUPLING DRIVE SPEED REDUCER
	192A02-25:1	60 RPM COUPLING DRIVE SPEED REDUCER
	192A02-50:1	30 RPM COUPLING DRIVE SPEED REDUCER
	192A02-100:1	18 RPM COUPLING DRIVE SPEED REDUCER
CD2	3L09 CD	DRIVE BEARING ASSEMBLY FOR 7/8" SHAFT
CD3	L075	5/8" X 5/8" LOVEJOY FLEXIBLE COUPLING
CD4	FCG	COUPLING GUARD
CD5	VAS-CD	OUTPUT COUPLING FOR 7/8" SHAFT
	VAS-CD-D	7/8" X 1/2" COUPLING FOR TRIPLEX OR QUAD
CD6	MS	MOTOR SPACER (4 REQUIRED)
CD7	MO-3	1PH 120/240 VAC 60HZ 1/2 HP EPFC 56 FRAME
	MO-4	90 VDC 1/2 HP TEFC 56/56C FRAME
	MO-6	3PH 230/460 VAC 60HZ 1/2 HP EPFC 56 FRAME
	MO-7	3PH 230/460 VAC 60HZ 1/2 HP TEFC 56 FRAME
	MO-8	1PH 120/240 VAC 60HZ 1/2 HP TEFC 56 FRAME
	MO-12	1PH 120/240 VAC 60HZ 1/3 HP TEFC 56C FRAME
	MO-12V	1PH 120/240 VAC 60HZ 1/2 HP TEFC 56C FRAME
	MO-13	1PH 120/230 VAC 60HZ 1/2 HP EPFC 56C FRAME
	MO-14	90 VDC 1/4 HP TENV 56C FRAME
	MO-14V	90 VDC 1/2 HP TEFC 56/56C FRAME
	MO-15	3PH 230/460 VAC 60HZ 1/3 HP TEFC 56C FRAME
	MO-15V	3PH 230/460 VAC 60HZ 1/2 HP TEFC 56C FRAME
	MO-16	3PH 240/480 VAC 60HZ 1/2 HP EPFC 56C FRAME
	MO-17	3PH 575 VAC 60HZ 1/3 HP TEFC 56C FRAME
	MO-18	1PH 115/230 VAC 50/60HZ 1/2 HP TEFC 56C FRAME
	MO-19	3PH 230/460 VAC 1/2 HP TENV INVERTER DUTY 56C
	MO-20	1PH 120/240 VAC 60HZ 1/2 HP SEVERE DUTY 56C
CD8	BP-CD	COUPLING DRIVE BASE PLATE
CD9	FMSR-60	60 RPM 56C FLANGED SPEED REDUCER
	FMSR-30	30 RPM 56C FLANGED SPEED REDUCER
	FMSR-18	18 RPM 56C FLANGED SPEED REDUCER
	FMSR-12	12 RPM 56C FLANGED SPEED REDUCER
	FMSR-6	6 RPM 56C FLANGED SPEED REDUCER
	FMSR-1	1 RPM 56C FLANGED SPEED REDUCER

**	MOTOR SUFFIX	GEAR DRIVE MOTOR OPTIONS (DISCONTINUED V-5)
	-2	1PH 120 VAC 60HZ 1/4 HP TENV (STANDARD)
	-5	3PH 230/460 VAC 60HZ 1/4 HP TENV
	-9	1PH 120/240 VAC 50/60HZ 1/4 HP TENV