

DIAPHRAGM PUMP MODEL NUMBERS

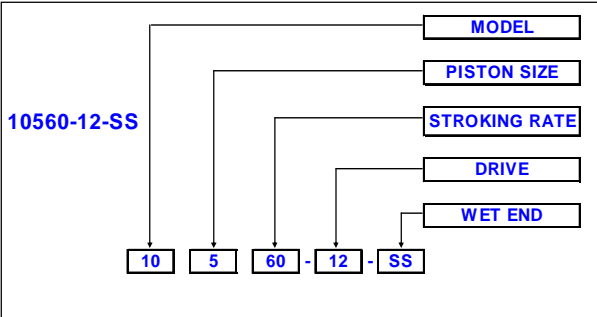

MAXIMUM FULL STROKE OUTPUT PER PUMP HEAD SIZE AT VARIOUS STROKE RATES VALUES BASED ON WATER
MINIMUM RECOMMENDED STROKE SETTING IS 20% OF MAXIMUM

MODEL

10	SIMPLEX-SINGLE DRIVE TO ONE PUMP HEAD
20	DUPLEX-SINGLE DRIVE TO TWO PUMP HEADS
30	TRIPLEX-SINGLE DRIVE TO THREE PUMP HEADS
40	QUAD-SINGLE DRIVE TO FOUR PUMP HEADS

PISTON SIZE

5	5/8" DIAMETER
7	1 1/2" DIAMETER
8	1" DIAMETER
9	2" DIAMETER

STROKING RATE

60	SIXTY STROKES PER MINUTE
30	THIRTY STROKES PER MINUTE
18	EIGHTEEN STROKES PER MINUTE
12	TWELVE STROKES PER MINUTE
06	SIX STROKES PER MINUTE
01	ONE STROKE PER MINUTE

DRIVE

00	LESS ANY DRIVE AND BASEPLATE	NO DRIVE
0CD	LESS MOTOR (COUPLING DRIVE CONFIGURATION)	COUPLING DRIVE
0FM	LESS MOTOR (FLANGE MOUNT CONFIGURATION)	FLANGE MOUNT
3	1/2 HP 120/240 VAC EXPLOSION PROOF FAN COOLED	COUPLING DRIVE
4	1/2 HP 90 VDC TOTALLY ENCLOSED FAN COOLED	COUPLING DRIVE
6	1/2 HP 240/480 VAC EXPLOSION PROOF FAN COOLED	COUPLING DRIVE
7	1/2 HP 240/480 VAC TOTALLY ENCLOSED FAN COOLED	COUPLING DRIVE
8	1/2 HP 120/240 VAC TOTALLY ENCLOSED FAN COOLED	COUPLING DRIVE
12	1/4 HP 120/240 VAC TOTALLY ENCLOSED FAN COOLED	FLANGE MOUNT
12V	1/2 HP 120/240 VAC TOTALLY ENCLOSED FAN COOLED	FLANGE MOUNT
13	1/3 HP 120/240 VAC EXPLOSION PROOF FAN COOLED	FLANGE MOUNT
14	1/4 HP 90 VDC TOTALLY ENCLOSED NON-VENTILATED	FLANGE MOUNT
14V	1/2 HP 90 VDC TOTALLY ENCLOSED FAN COOLED	FLANGE MOUNT
15	1/4 HP 240/480 VAC TOTALLY ENCLOSED NON-VENTILATED	FLANGE MOUNT
15V	1/2 HP 240/480 VAC TOTALLY ENCLOSED FAN COOLED	FLANGE MOUNT
16	1/2 HP 240/480 VAC EXPLOSION PROOF FAN COOLED	FLANGE MOUNT
17	1/3 HP 575 VAC TOTALLY ENCLOSED FAN COOLED	FLANGE MOUNT
18	1/3 HP 115/230 VAC 50/60 HZ TOTALLY ENCLOSED FAN COOLED	FLANGE MOUNT
19	1/2 HP 240/480 VAC TOTALLY ENCLOSED NON-VENTILATED INVERTER DUTY	FLANGE MOUNT
20	1/2 HP 115/230 VAC TOTALLY ENCLOSED NON-VENTILATED SEVERE DUTY	FLANGE MOUNT

WET END

BLANK	CARBON STEEL
SS	303 STAINLESS STEEL
S6	316 STAINLESS STEEL
C20	ALLOY 20 STAINLESS STEEL
HC	ALLOY 276 STAINLESS STEEL

5/8" DIA PISTON 100 PSI MAX

STROKE RATE	FULL STROKE OUTPUT		
	ML/MIN	GPH	GPD
01	6	0.1	2.4
06	36	0.6	14.4
12	72	1.2	28.8
18	108	1.8	43.2
30	180	3	72
60	360	6	144

1" DIA PISTON 100 PSI MAX

STROKE RATE	FULL STROKE OUTPUT		
	ML/MIN	GPH	GPD
01	15	0.25	6
06	90	1.5	36
12	180	3	72
18	270	4	96
30	450	7	168
60	900	14	336

1 1/2" DIA PISTON 100 PSI MAX

STROKE RATE	FULL STROKE OUTPUT		
	ML/MIN	GPH	GPD
01	30	0.5	12
06	180	3	72
12	360	6	144
18	540	9	216
30	900	15	360
60	1800	30	720

2" DIA PISTON 100 PSI MAX

STROKE RATE	FULL STROKE OUTPUT		
	ML/MIN	GPH	GPD
01	60	1	24
06	360	6	144
12	720	12	288
18	1080	18	432
30	1800	30	720
60	3600	60	1440

V-6 MINI-PUMP 100 PSI MAX

STROKE RATE	FULL STROKE OUTPUT		
	ML/MIN	GPH	GPD
2	2.5	0.04	1
6	8	0.12	3
12	15	0.25	6
30	63	1	24
60	126	2	48

V-6 MINI PUMP

V-6-60	60 STROKES PER MINUTE	48 GPD MAX @ 100 PSI MAX	1/20 HP TEFC
V-6-30	30 STROKES PER MINUTE	24 GPD MAX @ 100 PSI MAX	1/20 HP TEFC
V-6-12	12 STROKES PER MINUTE	6 GPD MAX @ 100 PSI MAX	1/20 HP TEFC
V-6-6	6 STROKES PER MINUTE	3 GPD MAX @ 100 PSI MAX	1/20 HP TEFC
V-6-2	2 STROKES PER MINUTE	1 GPD MAX @ 100 PSI MAX	1/20 HP TEFC